

VOLVO PENTA INDUSTRIAL DIESEL

TAD1640-1642VE-B

TAD1640-1642VE-B is a powerful, reliable and economical Versatile Diesel Engine range built on the Volvo in-line six concept.

Low cost of ownership

World class fuel efficiency combined with a reliable engine gives high uptime as well as low cost of ownership.

Compact and simple installation

As optional equipment all material needed in order to install the engine can be ordered from Volvo Penta. Installation guidelines as well as drawings and CAD models are easy to access. The result is an engine that is easy to install with minor impact on existing machine layout.

Durability & low noise

Designed for the easiest, fastest and most economical installation. Well balanced to produce smooth operation with low noise level, featured with high torque.

Power and torque

Maximum power and torque available at low rpm. As a result noise as well as fuel consumption is very low. Useful engine speed for the TAD1640-1642VE-B is due to power and torque layout very flexible.

Low exhaust emission

Efficient injection as well as robust engine design contributes to excellent combustion and low fuel consumption. TAD1640-1642VE-B complies with EU Stage II / EPA Tier 2 emissions.

Easy service & maintenance

Easily accessible service and maintenance points contribute to the ease of service of the engine. As optional equipment possible to remote mount filters and service points.

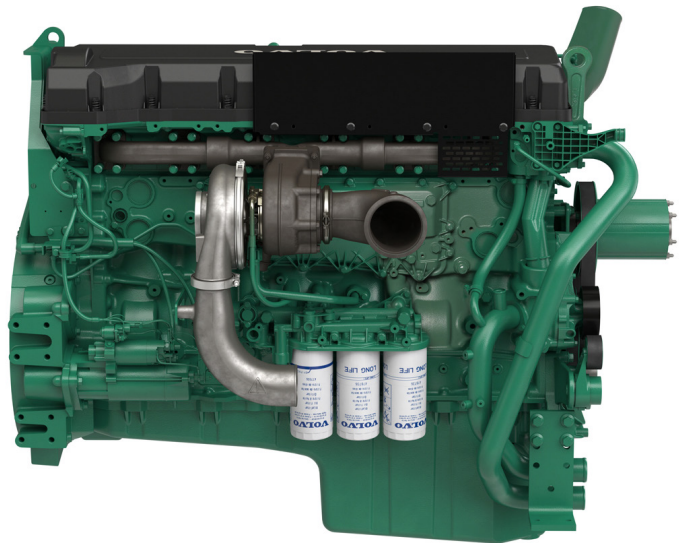

Features & Benefits

- Low cost of ownership
- Proven and straight-forward design
- Compact and simple installation
- High power and torque available at low engine speed
- Wide range of optional equipment, please see order specification

Technical description

Engine and block

- Cast iron cylinder block
- Wet, replaceable cylinder liners
- Replaceable valve guides and valve seats
- Overhead camshaft and four valves per cylinder

Lubrication system

- Full flow disposable spin-on oil filter
- Gear type lubricating oil pump, gear driven by the transmission
- Oil level sensor at startup

Fuel system

- Electronic high pressure unit injectors
- Fuel prefilter with water separator and water-in-fuel indicator / alarm
- Gear driven low-pressure fuel pump

- Fine fuel filter with manual feed pump and fuel pressure switch

Cooling system

- Available as Power Pac or base engine.
- Belt driven coolant pump with high degree of efficiency

Turbocharger

- Electronically controlled Waste-gate

Electrical system

- Engine Management System 2 (EMS 2), an electronically controlled processing system which optimizes engine performance.
- The instruments and controls connect to the engine via the CAN SAE J1939 interface. Options for engine control equipment.

**VOLVO
PENTA**

TAD1640-1642VE-B

Technical Data

General

Engine designation TAD1640-1642VE-B
 No. of cylinders and configuration in-line 6
 Method of operation 4-stroke
 Bore, mm (in.) 144 (5.67)
 Stroke, mm (in.) 165 (6.50)
 Displacement, l (in³) 16.12 (984)
 Compression ratio 16.8
 Wet weight, engine only, kg (lb) 1440 (3175)
 Oil system capacity incl filters, liter (US gal) 48 (12.68)

Engine	kW	Hp	rpm	Nm
TAD1640VE-B	405	551	1900	2760
TAD1641VE-B	450	612	1800	2910
TAD1642VE-B	515	700	1800	3220

For details see Technical Data

Dimensions TAD1640-1642VE-B

Not for installation

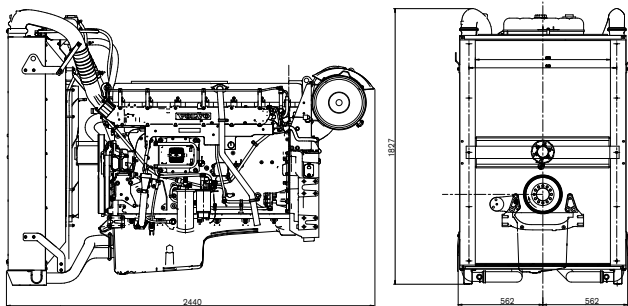

Note! Not all models, standard equipment and accessories are available in all countries. All specifications are subject to change without notice. The engine illustrated may not be entirely identical to production standard engines.

Power Standards

The engine performance corresponds to ISO 3046, BS 5514 and DIN 6271. The technical data applies to an engine without cooling fan and operating on a fuel with calorific value of 42.7 MJ/kg (18360 BTU/lb) and a density of 0.84 kg/litre (7.01 lb/US gal, 8.42 lb/Imp gal), also where this involves a deviation from the standards.

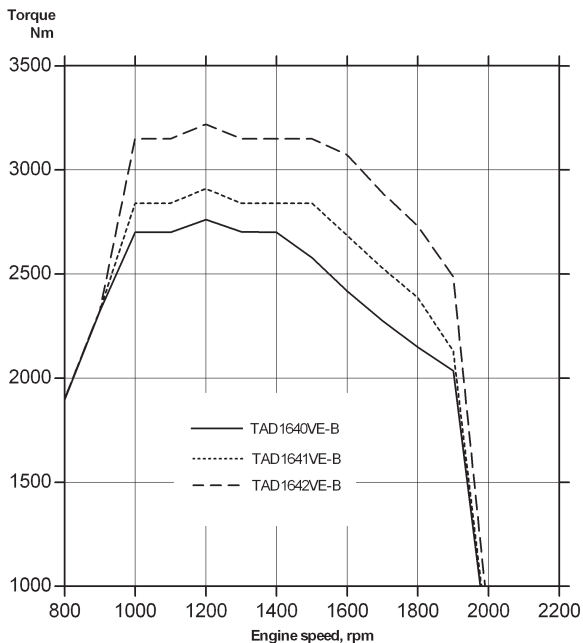
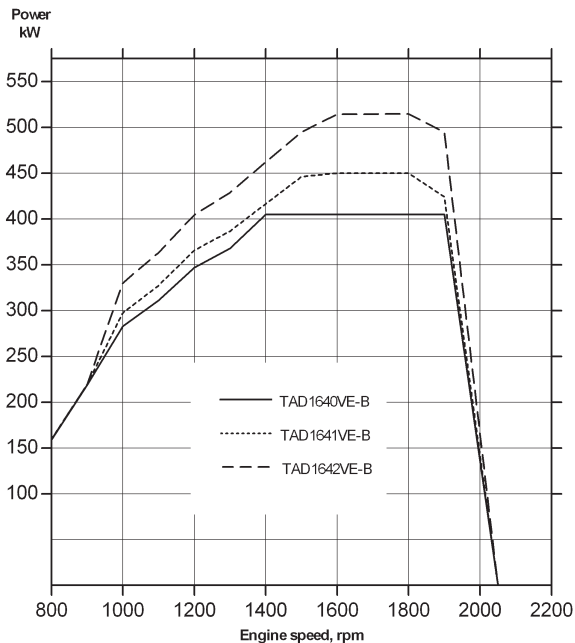

VOLVO PENTA

AB Volvo Penta
 SE-405 08 Göteborg, Sweden
 www.volvopenta.com