

VOLVO PENTA INBOARD DIESEL

D4-225

165 kW (225 hp) crankshaft power acc. to ISO 8665

Performance for marine use

Volvo Penta's 4-cylinder D4-225 is developed from the latest design in modern diesel technology. The engine has common rail fuel injection system, double overhead camshafts, 4 valves per cylinder, turbocharger and aftercooler. Together with a large swept volume and the EVC system (Electronic Vessel Control), this results in world-class diesel performance, combined with low emissions.



D4-225 with HS45AE reverse gear

World-class performance

The common rail fuel injection system, controlled by EVC, in combination with a large swept volume, ensures outstanding torque during acceleration, with virtually no sign of smoke. This matched with the engine's high load carrying capability creates a sporty feeling and power, when needed.

Compact and robust

The engine is extremely compact for its large swept volume and high output. With the rear-end transmission, driving the high-pressure injection pump and the camshafts, a high degree of integrated systems, a high-efficiency aftercooler, a marinization performed with very few hoses, and a fully symmetric engine, the package simply gets that compact.

The rigid cast-iron cylinder block and head, combined ladder frame and balance shafts, and exactly controlled (up to three steps) fuel injection gives excellent onboard comfort with low noise and vibration levels.

EVC-E

The next generation of the proven Electronic Vessel Control offers further enhancements to the driver experience.

The robust E-key with touch less technology is standard.

Ergonomically designed controls engage smoothly and allow for maneuvering with fingertip precision. Pushbuttons integrated on the control give easy access to optional functions such as Low Speed and Single Lever Control.

Complete the helm with your choice of easy to read gauges and displays, including the 7" color display. Add the trip computer function for accurate fuel management and minimized environmental impact. Engine synchronization is standard in twin installations.

A propulsion package fully matched, tested and supported by one company

Volvo Penta's hydraulically shifted reverse gear has been specially developed with a view to increasing the standard of comfort on board.

Matched with the characteristics of the D4 engine, the hydraulic shifting mechanism and a gear technology that uses bevel gears throughout the gear train, we have developed a complete package for high torque, operational reliability and reduction of engine noise and vibrations.

The combination of 8° down angle, large drop center and small dimensions provides for optimized installations. V-drives are also available.

In order to get full benefit of the EVC system the reverse gear is equipped with electric shifting valve.

Meeting new emission standards

The common rail injection system in combination with electronics and an advanced combustion system are setting new standards in minimizing noxious emissions and particulates. The engine complies with IMO NOx limits and the comprehensive emission requirements EU RCD and US EPA Tier 3.

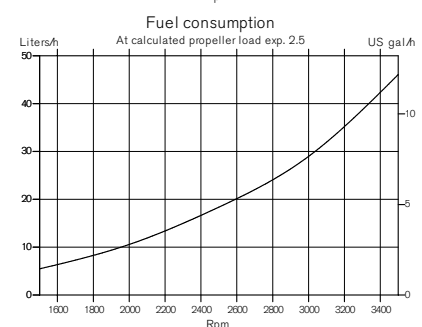
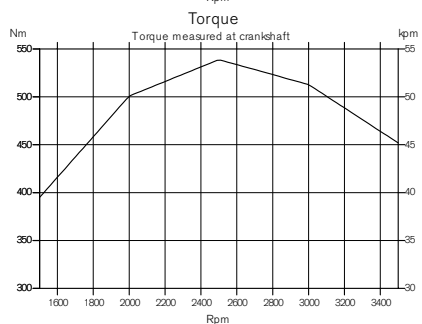
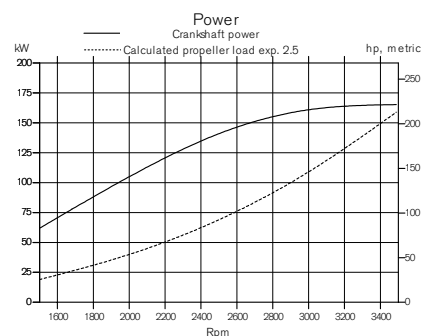

**VOLVO
PENTA**

D4-225

Technical description:

Engine block and head

- Cylinder block and cylinder head made of cast-iron
- Combined ladder frame and balance shafts
- 4-valve technology with hydraulic lash adjusters
- Double overhead camshafts
- Oil-cooled pistons with two compression rings and one oil scraper ring
- Integrated cylinder liners
- Replaceable valve seats
- Five-bearing crankshaft
- Rear-end transmission

Engine mounting

- Flexible engine mounting

Lubrication system

- Easily replaceable separate full-flow and by-pass oil filter
- Seawater-cooled tubular oil cooler

Fuel system

- Common rail fuel injection system
- Control unit for processing the injection
- Fine filter with water separator and alarm

Air inlet and exhaust system

- Air filter with replaceable insert
- Crankcase gases vented into the air inlet
- Exhaust elbow or exhaust riser
- Freshwater-cooled turbocharger
- Loss of sea water alarm

Cooling system

- Thermostatically regulated freshwater cooling
- Tubular heat exchanger with separate large volume expansion tank
- Coolant system prepared for hot water outlet
- Easily accessible seawater impeller pump

Electrical system

- 12V two-pole electrical system
- 115A marine alternator with Zener-diodes to protect the system from peak voltage, and integrated charging regulator with battery sensor cable for maximum use of alternator
- Fuses with automatic reset
- Auxiliary stop button

Instruments/control

- Complete instrumentation including key switch and interlocked alarm
- EVC monitoring panels for single or twin installations
- Electronic shift and throttle

- Plug-in connections

Reverse gear

- Reverse gear with matched drop center and 8° down angle for compact installation and minimum propeller shaft angle. V-drive available.
- Bevel gears which results in smooth running at all speeds
- Hydraulically operated clutch for smooth shifting
- Electrical shifting performed by electromagnetic valves
- When under sail propeller shaft can rotate 24 hours without engine start
- Seawater-cooled oilcooler
- Low Speed as option for HS63AE/IVE

Accessories

An extensive range of accessories are available. For detailed information, please see the Accessories & Maintenance Parts catalog (www.volvopenta.com).

Option

U.S.C.G./MED (SOLAS) kit available.

Contact your local Volvo Penta dealer for further information.

Not all models, standard equipment and accessories are available in all countries. All specifications are subject to change without notice.

The engine illustrated may not be entirely identical to production standard engines.

Technical Data

Engine designation	D4-225 I
Crankshaft power, kW (hp)	165 (225)
Propeller shaft power, kW (hp)	160 (218)
Engine speed, rpm	3500
Displacement, l (in ³)	3.7 (224)
Number of cylinders	4
Bore/stroke, mm (in.)	103/110 (4.05/4.33)
Compression ratio	17.5:1
Dry weight with HS45AE, kg (lb)	546 (1204)
Ratio HS45AE	2.03:1, 1.51:1
Ratio HS63AE	2.5:1
Ratio HS63IVE	2.48:1, 1.99:1

Duty rating: R4 & R5

Technical data according to ISO 8665. With fuel having an LHV of 42,700 kJ/kg and density of 840 g/liter at 15°C (60°F). Merchant fuel may differ from this specification which will influence fuel consumption.

The engine complies with IMO NOx and the comprehensive emission requirements US EPA Tier 3 and EU RCD.

Dimensions D4-225/HS45AE

Not for installation

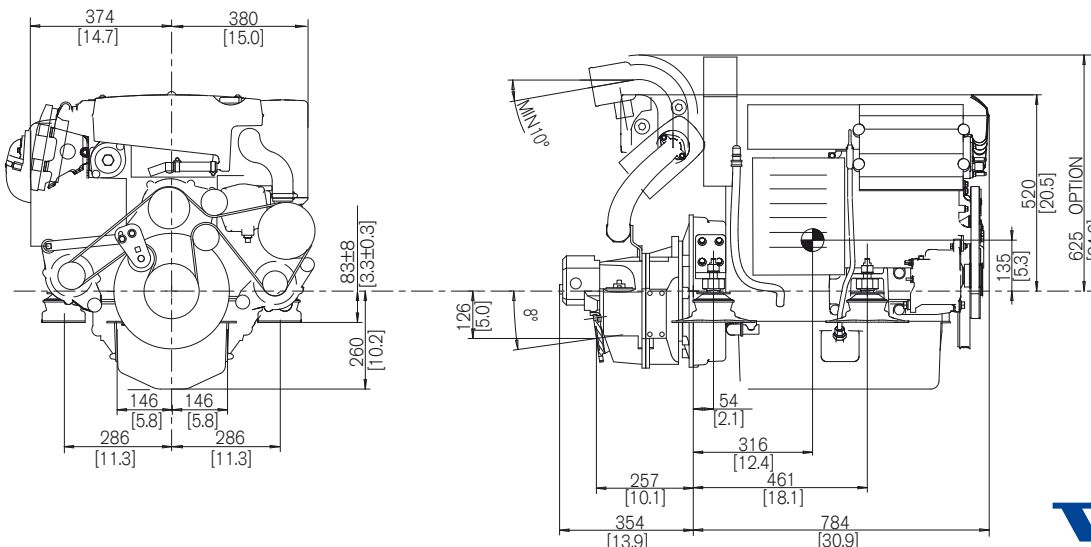

VOLVO PENTA

AB Volvo Penta
SE-405 08 Göteborg, Sweden
www.volvopenta.com